

S13705 IMPRESSA XJ5 silber GII 684
Ausgabe: 13.11.2015



Der Ersatzteilkatalog gilt für folgende Artikel:
13705 IMPRESSA XJ5 GII silber EU

Legende:

(1) Gehäuseteile und Wassertank

S13705_01

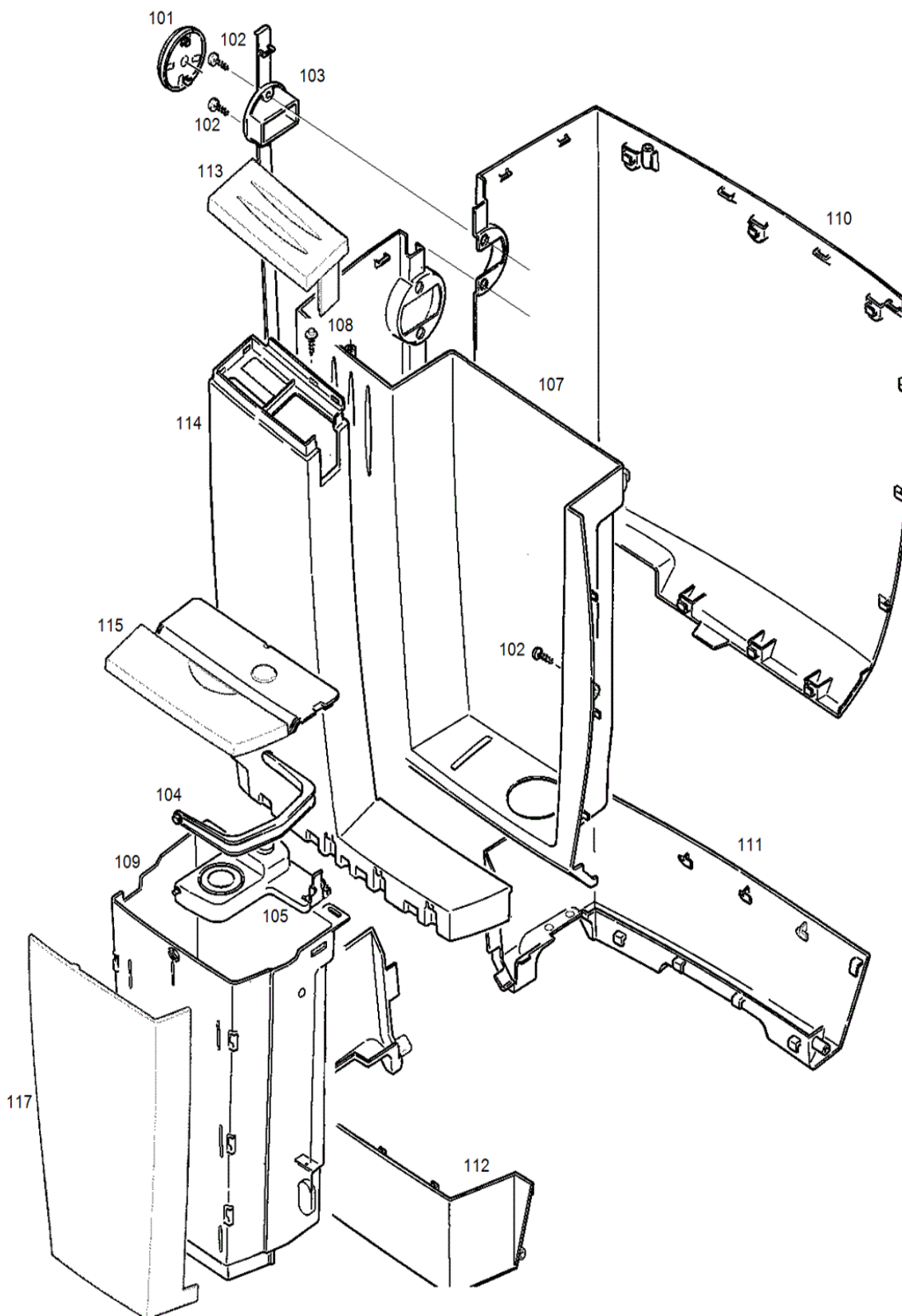

(2) Gehäuseteile

S13705_02

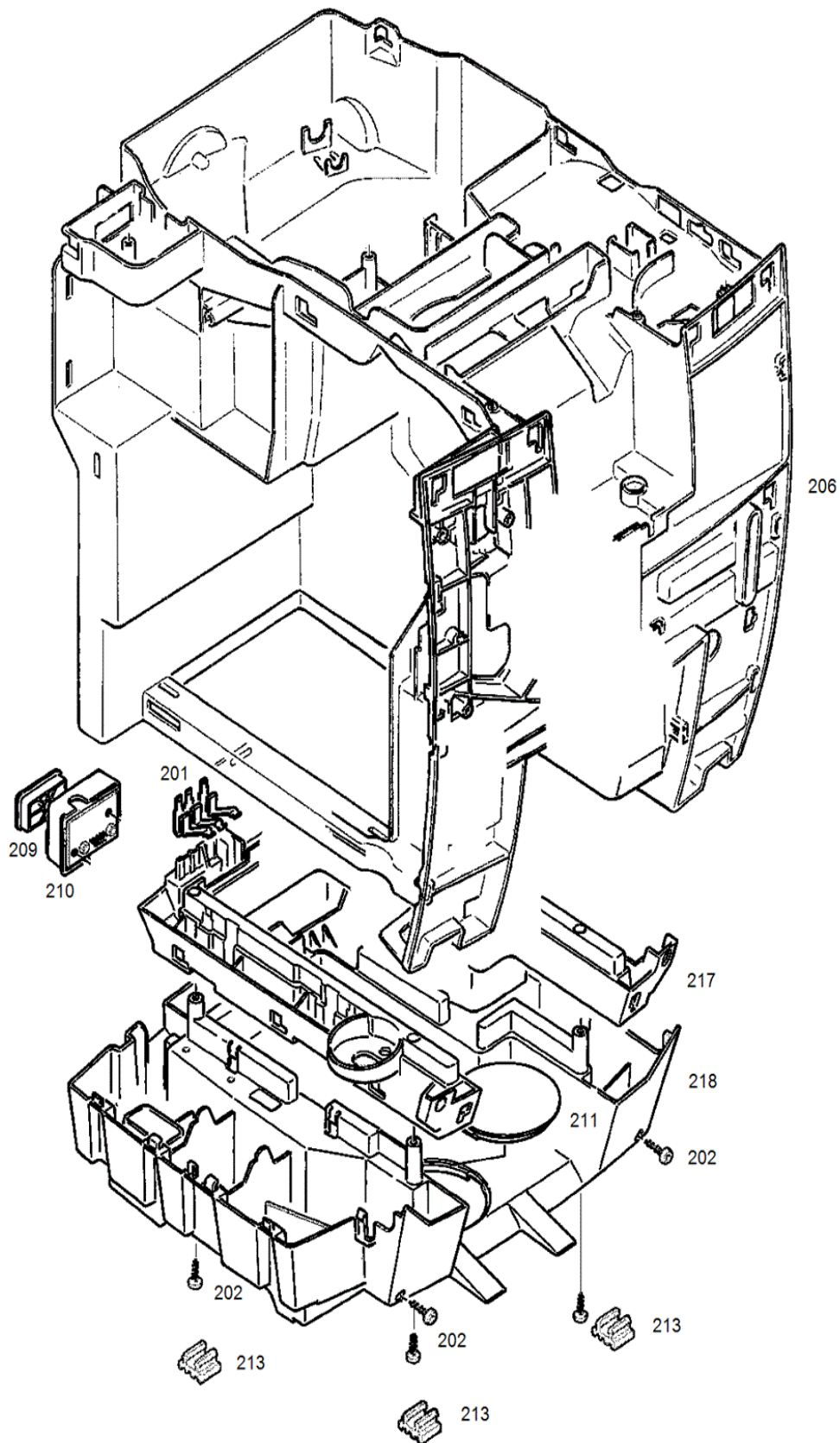

(3) Fronttüre

S13705_03

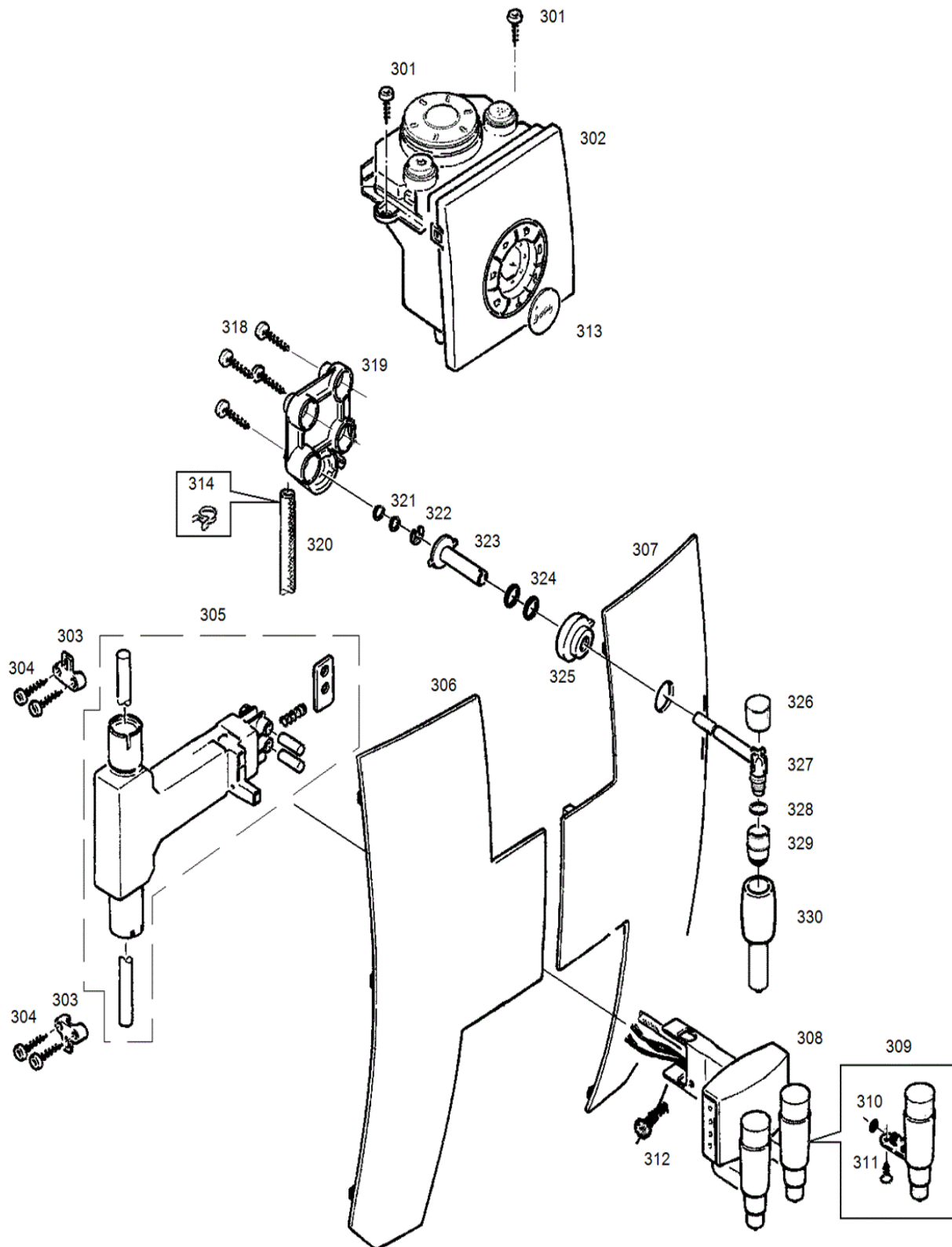

(4) Gehäusedeckel

S13705_04

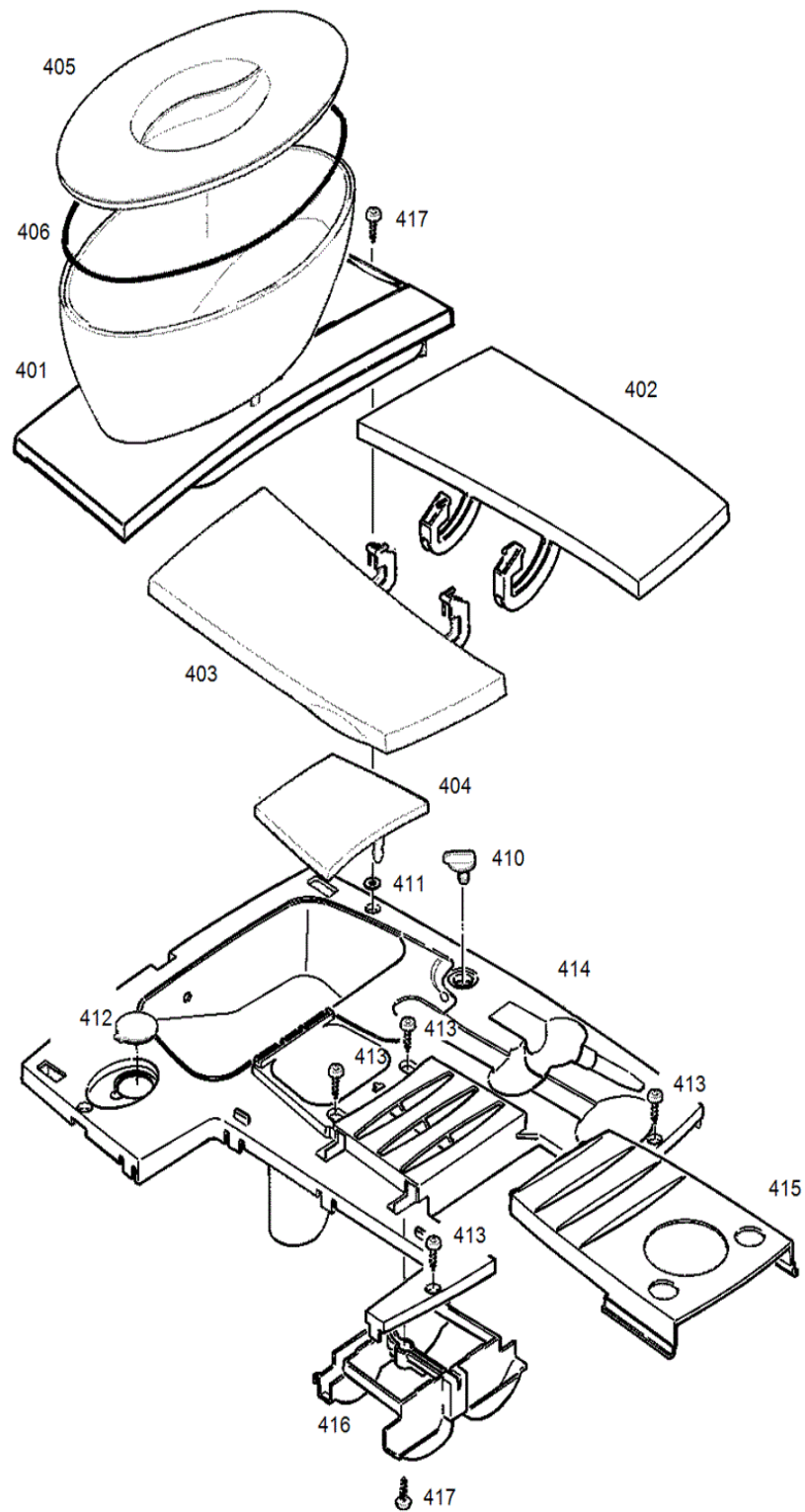

(5) Schale

S13705_05

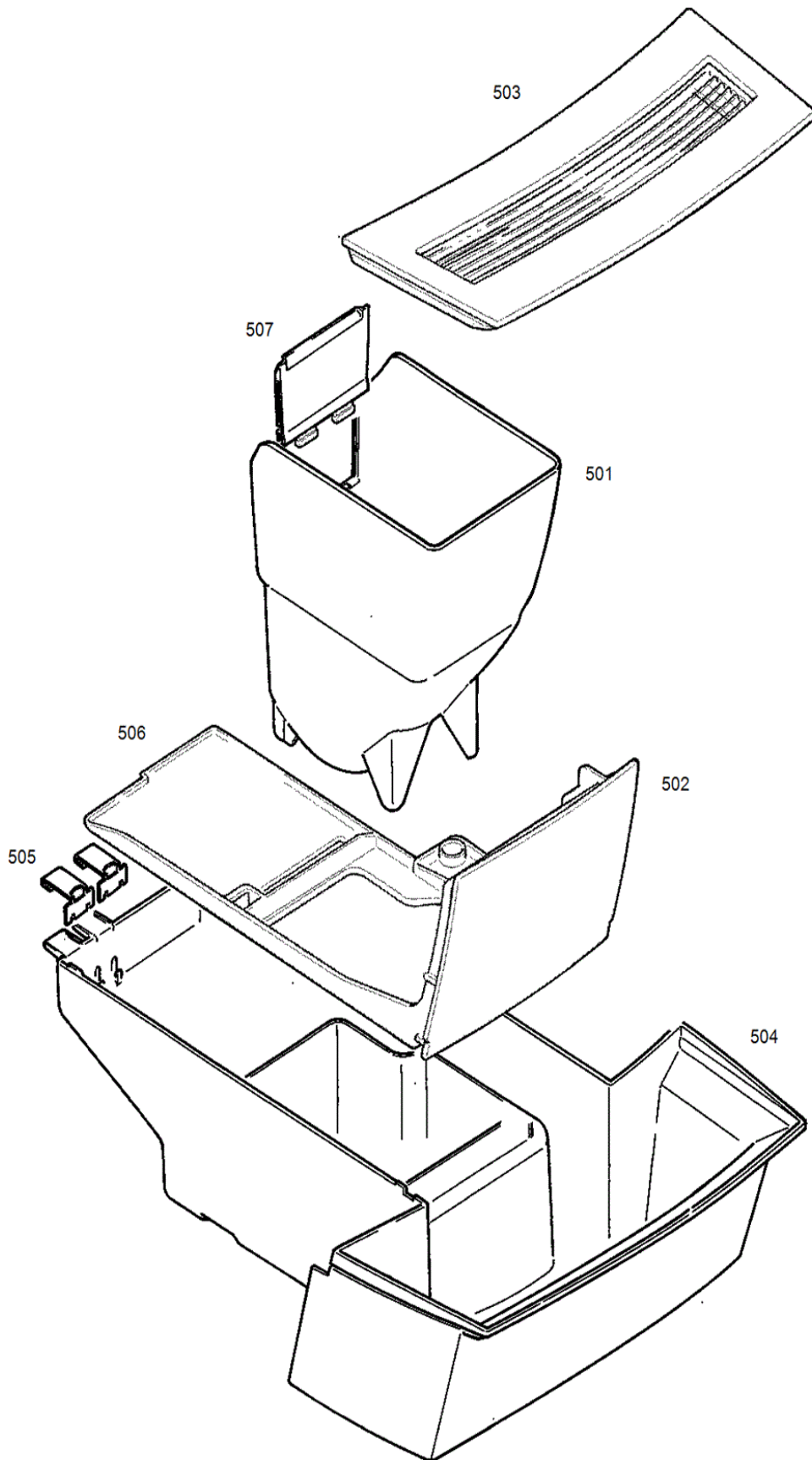

(6) Leistungsprint

S13705_06

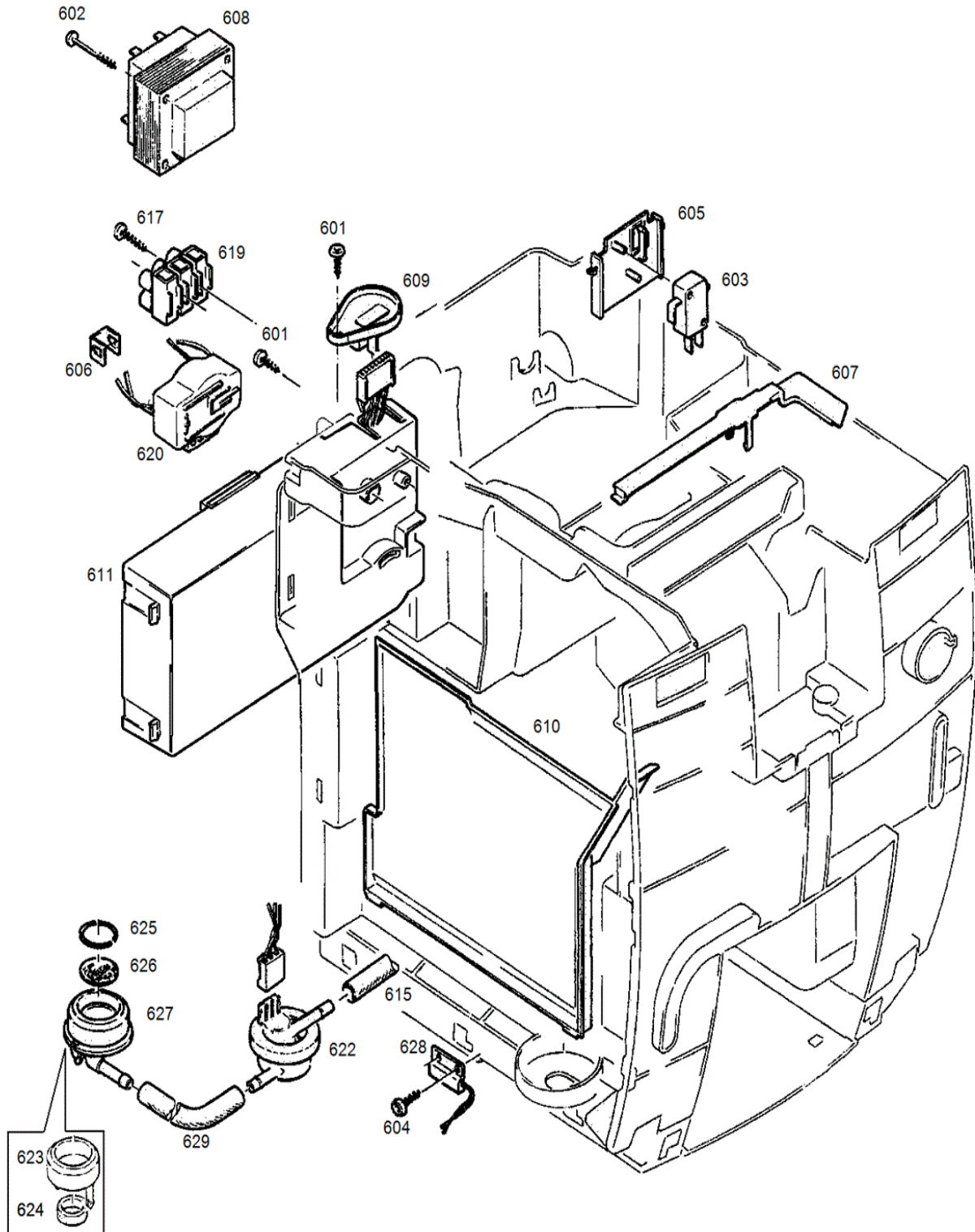

(7) Fluidsystem

S13705_07

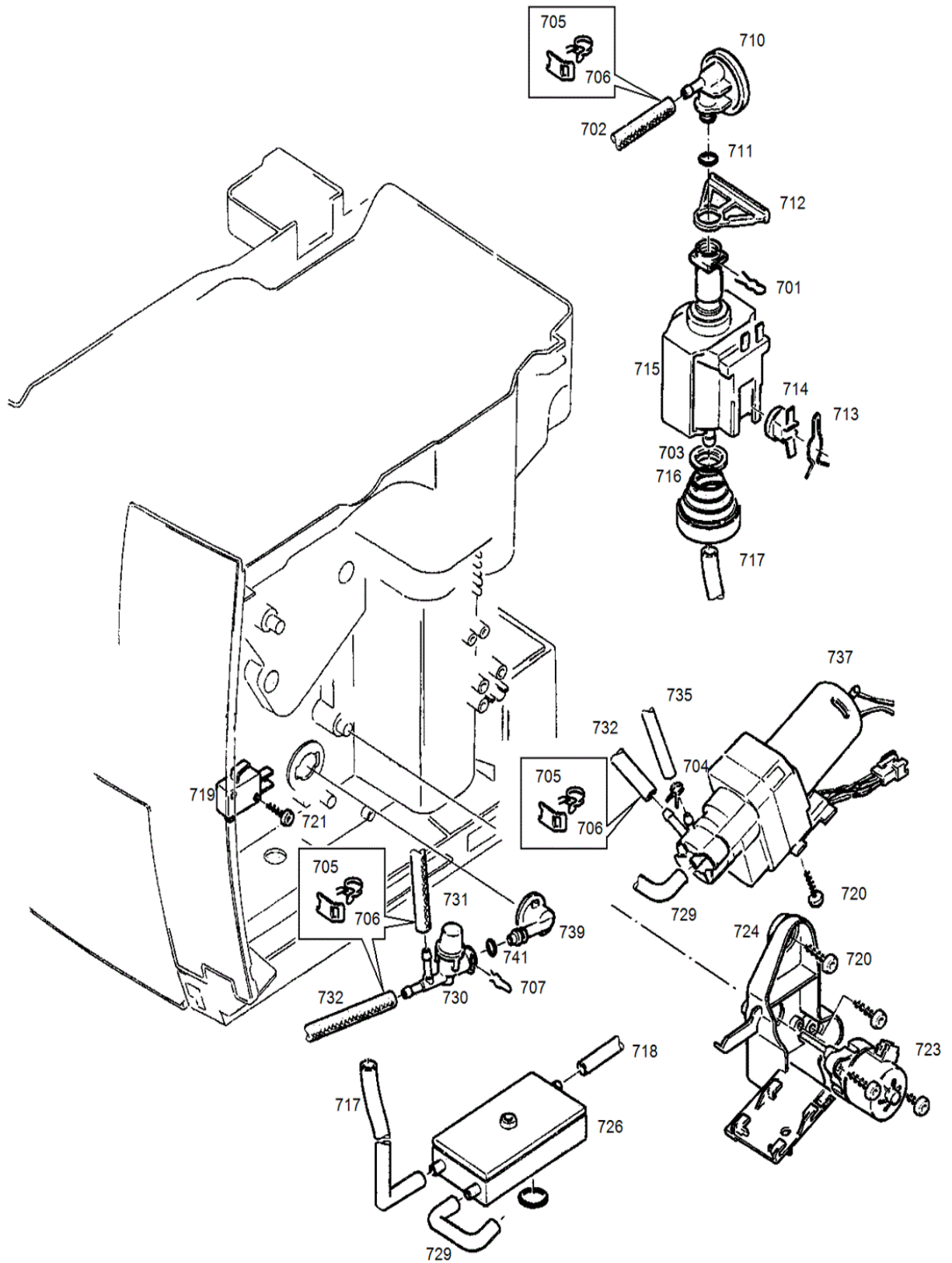

Art.-Nr.	Pos	Bezeichnung	Variante	Lager	SC
	0701	Klammer D=5mm brüniert		x	
	0702	Schlauch Silikon/Gewebe 315mm		x	
	0703	Pumpenauflage blau		x	
	0703	Pumpenauflage		x	
	0704	Schlauchklemme 7.0-7.5 RoHS		x	
	0705	Klemmfeder D=1.3mm V2		x	
	0706	Sicherungsblech zu Klemmfeder		x	
	0707	Klammer D=5mm brüniert		x	
	0710	Membrandämpfungselement V3		x	
	0711	O-Ring 100 Stk (einzeln 58775)		x	
	0712	Pumpenstütze schwarz 70 Sh		x	
	0713	Klammer Thermostat Inox		x	
	0714	Thermostat 115C/10A 1NT01L		x	
	0715	Pumpe SAP.HP4.V03 S EU V2		x	
	0716	Dämpfungselementkit		x	
	0717	Formschlauch Silikon		x	
	0718	Silikonschlauch 9x5x230mm		x	
	0719	Mikroschalter 125-250V AC		x	
	0720	Schraube KST/PT 3.5x12 vz-blau		x	
	0721	Schraube kst/PT 3.0x20		x	
	0723	Drainagemotor UCL13N04B1UZ12		x	
	0724	Träger Schrittmotor schwarz		x	
	0726	Wärmetauscher kpl. Eloxiert		x	
	0729	Schlauch U-Form		x	
	0730	Auslaufventil Y kpl.		x	
	0731	Schlauch Silikon/Gewebe 210mm		x	
	0732	Schlauch Silikon/Gewebe 90mm		x	
	0735	Schlauch Silikon/Gewebe Di 3.0		x	
	0737	Mehrwegventil kpl.		x	
	0739	Fluid-Andockbüchse schwarz		x	
	0741	O-Ring 4.48x1.78 EPDM		x	

(8) Erhitzer

S13705_08

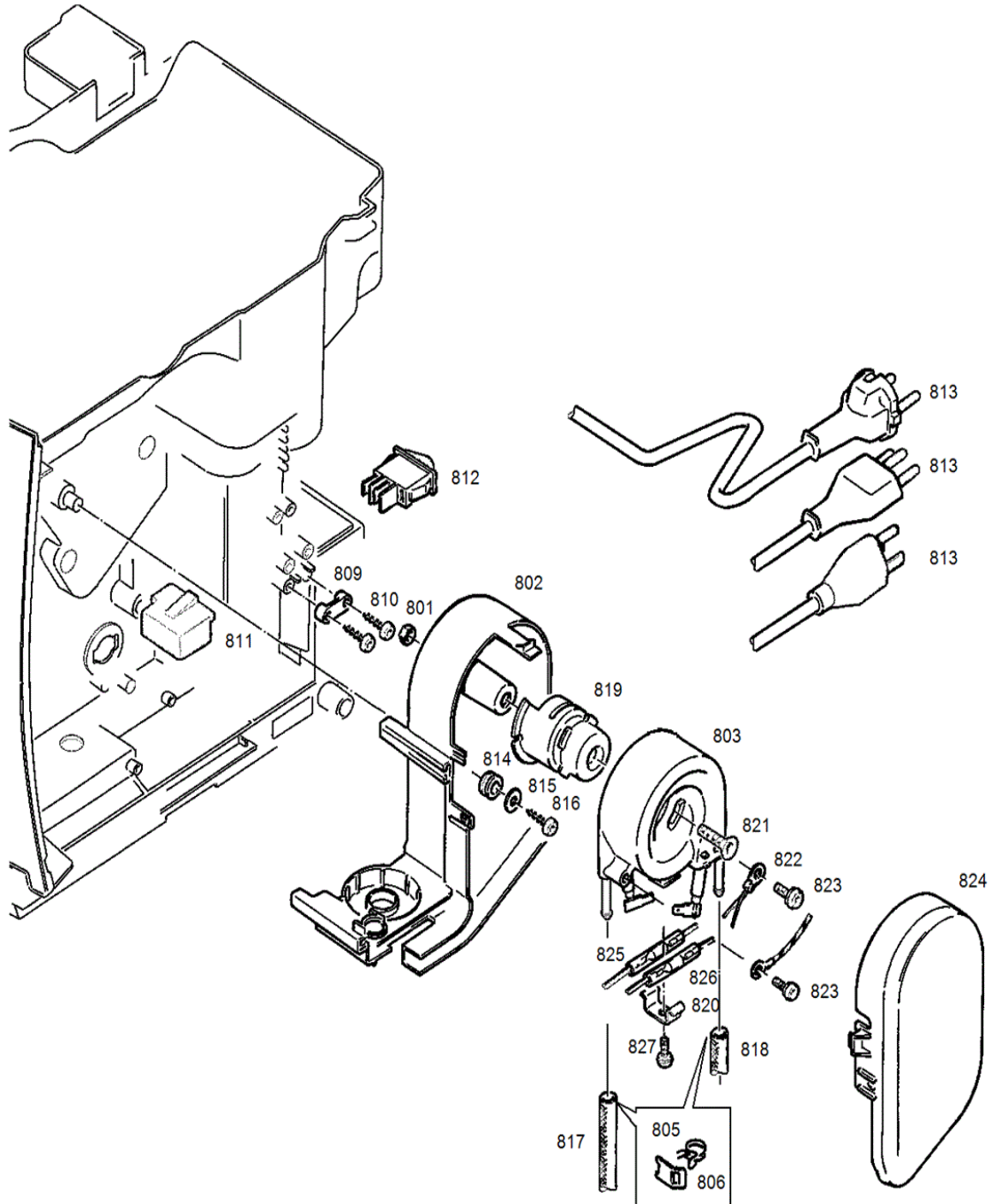

(9) Mahleinheit

S13705_09

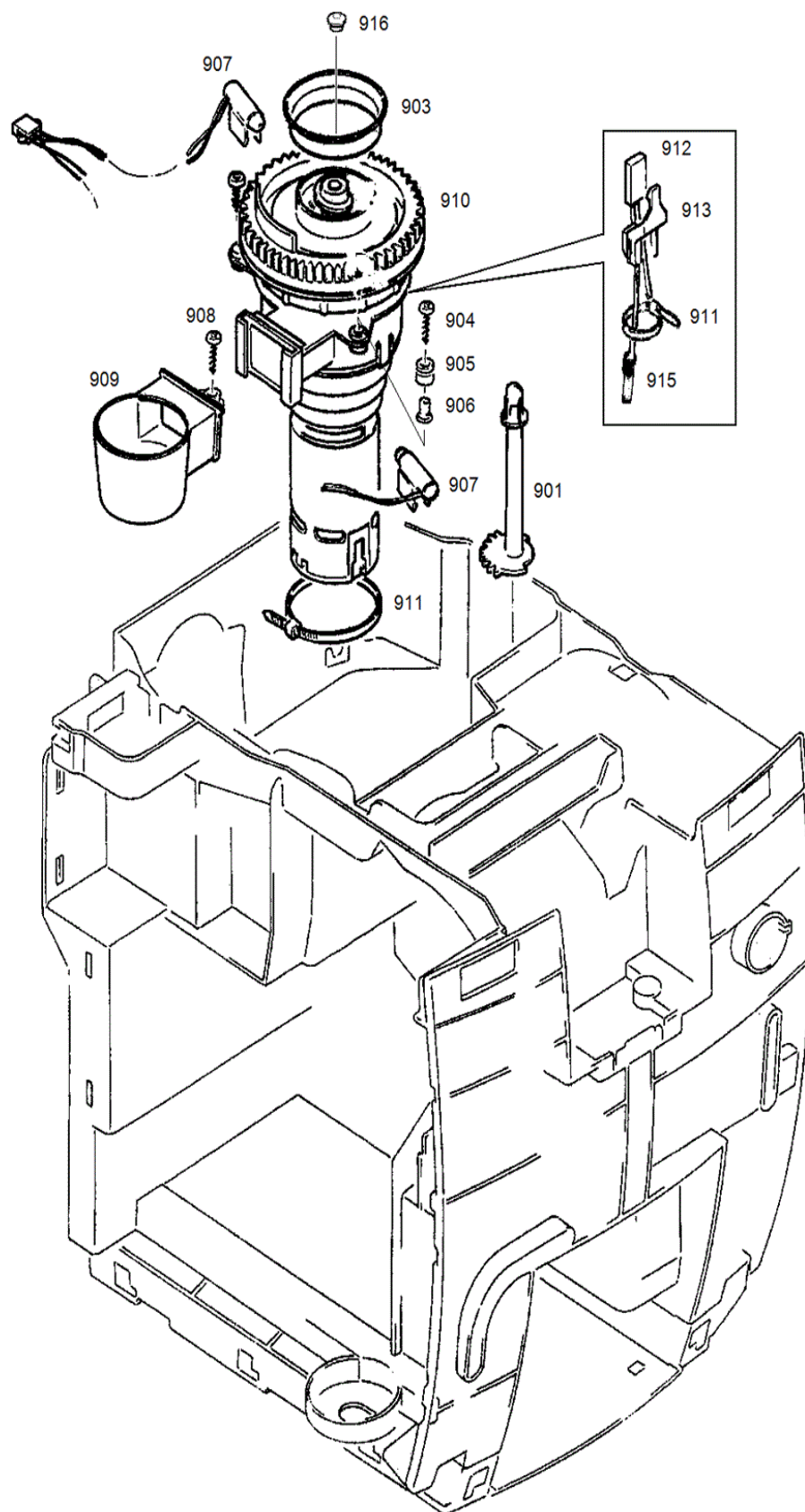

(10) Brüheinheit und Antrieb

S13705_10

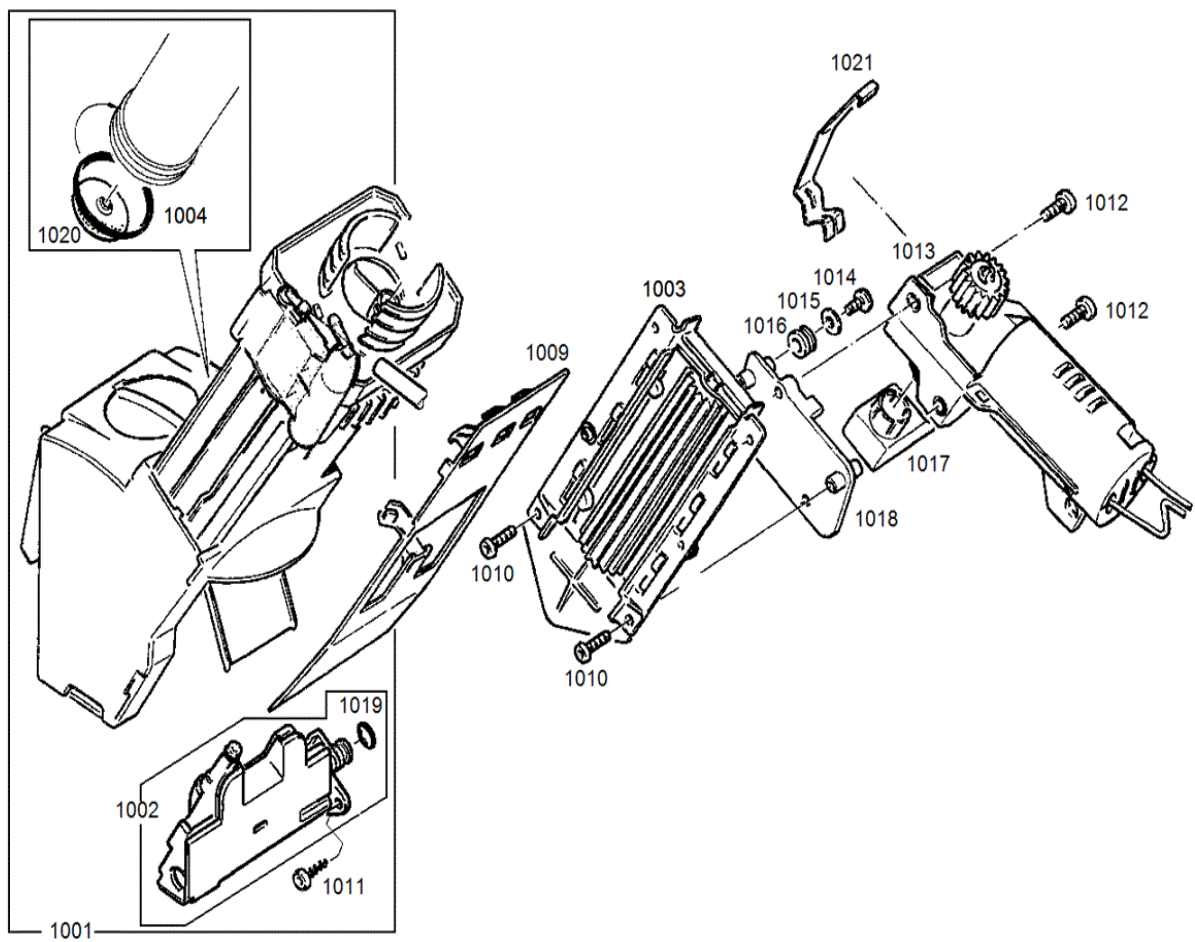

(11) Beilage

S13705_11

7

1101



Verpackung/
Packing

1110



Betriebsmittel/
Operational funds

1120



Hinweise/
References

1140

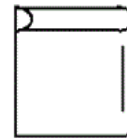

Bedienungsanleitung/
Operating instructions

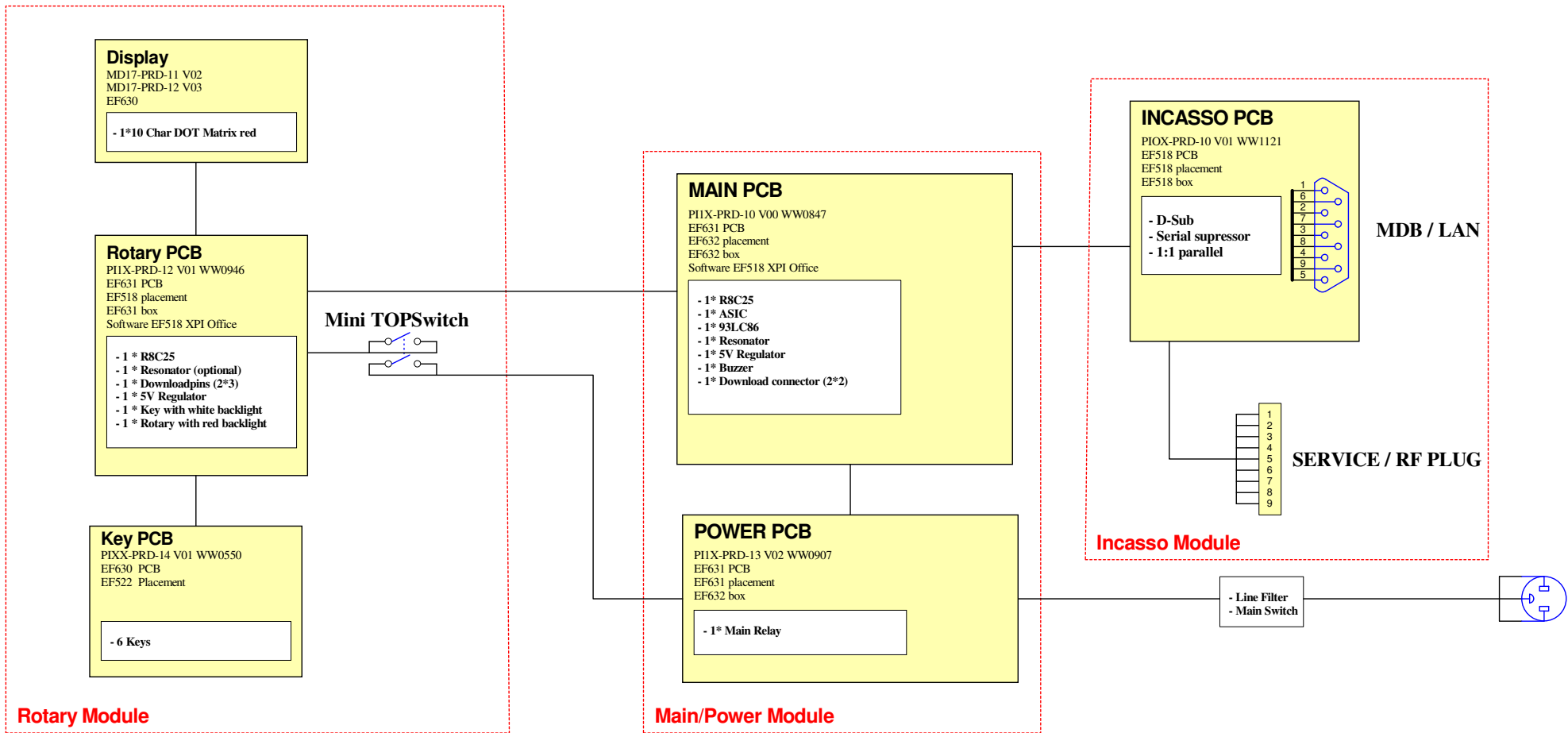

change notice	date	drawn	checked	approved	title
MD17-PRD-12 V02 to MD17-PRD-12 V03	120216	Ryser Daniel			EF518 XJ Office Blockdiagram Overview size A3 drawingnumber EF518 BL_0000 V00.SCHDOC Revision 120216
Delete Eeprom on Rotary PCB	111104	Ryser Daniel			
change blockdiagram title to EF518 XJ Office	110526	Foltrauer Heinz			



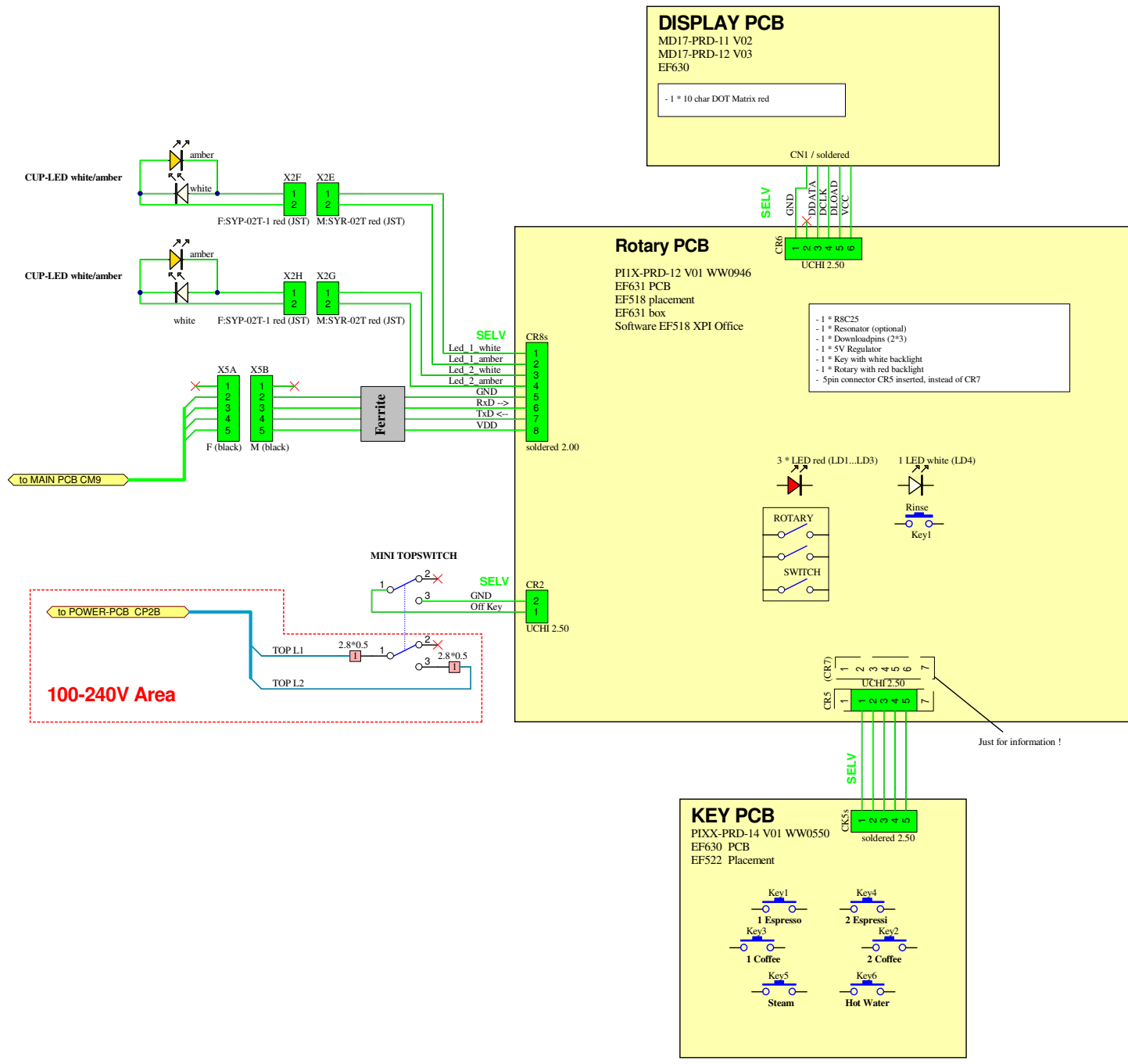

change notice	date	drawn	checked	approved	title
MD17-PRD-12 V02 to MD17-PRD-12 V03	120216	Ryser Daniel			EF518 XJ Office Blockdiagram Rotary Module size A3 drawingnumber EF518 BL_0002 V00.SCHDOC Revision 120216
Delete Eeprom on Rotary PCB	111104	Ryser Daniel			
Change blockdiagram title to EF518 XJ Office	110526	Foltrauer Heinz			

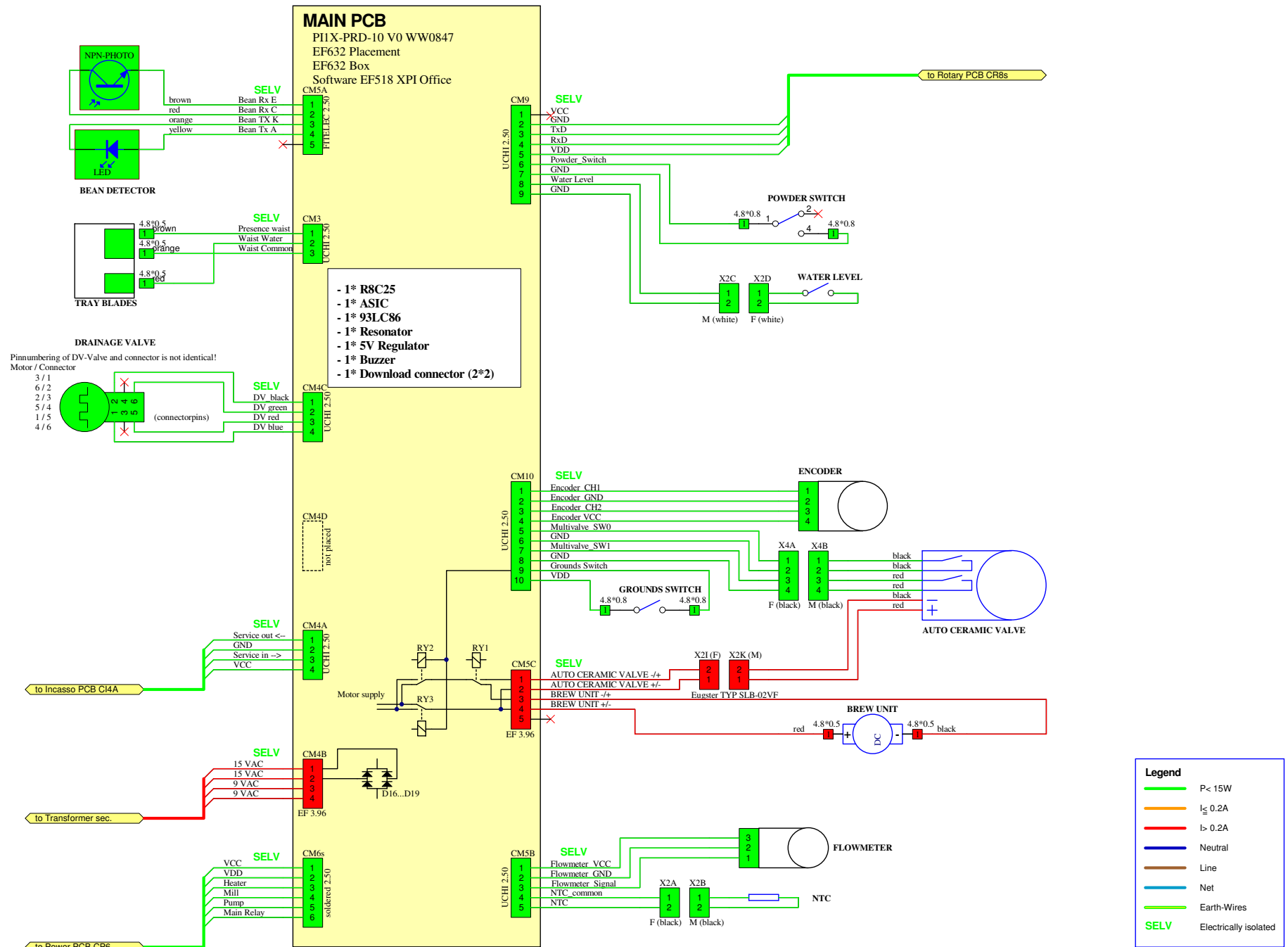

change notice	date	drawn	checked	approved	title
4 Delete UWK-Inductors for Brew Unit	111202	Ryser Daniel			TOP tronic title EF518 XJ Office Blockdiagram Main size A3 drawingnumber EF518 BL_0001 V00.SCHDOC Revision 111202
change blockdiagram title to EF518 XJ Office	110526	Foltrauer Heinz			
Delete Pinchvalve Stepper - not used in EF518 XPI Office; Correct placement and box to EF632	110223	Ryser Daniel			

220-240V
50/60Hz

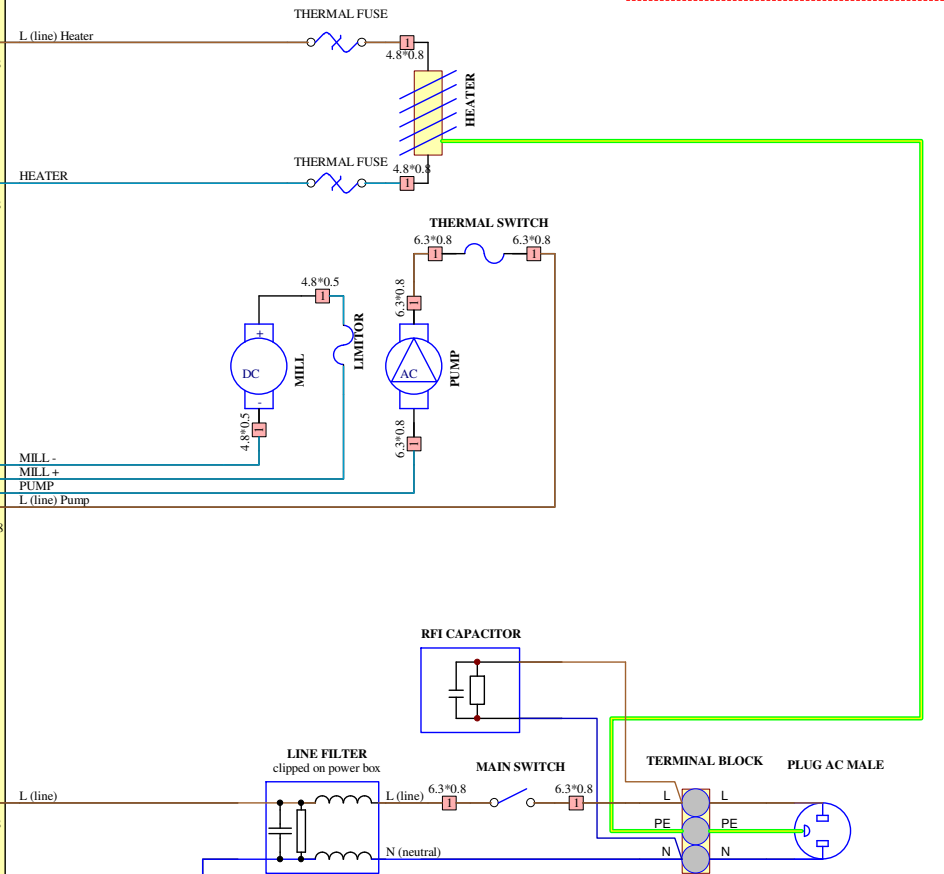
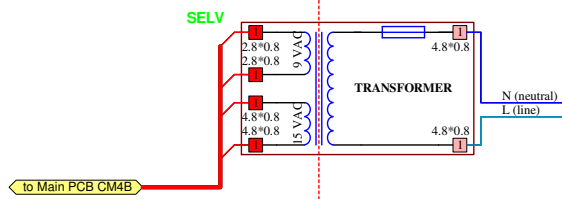
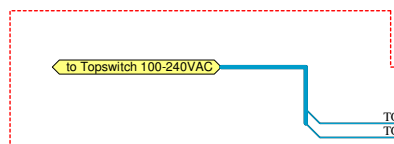
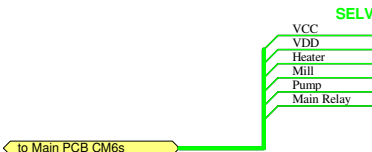
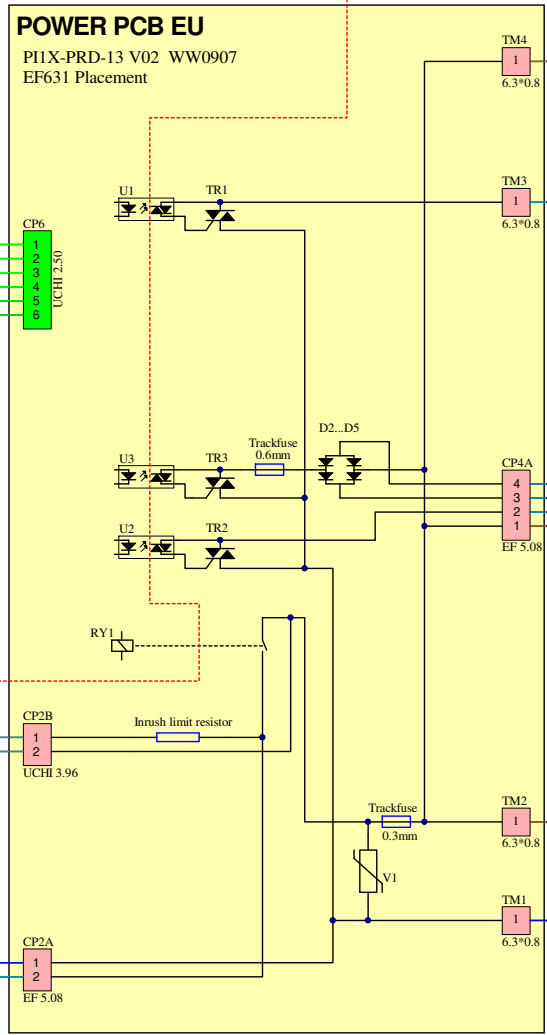

220-240V Area

Legend

- P < 15W
- I ≤ 0.2A
- I > 0.2A
- Neutral
- Line
- Net
- Earth-Wires
- SELV Electrically isolated

change notice	date	drawn	checked	approved	title
Integrate RFI-Capacitor	120125	Ryser Daniel			EF518 XJ Office Blockdiagram Power 220-240V 50/60Hz size A3 drawingnumber EF518 BLA0001 V00.SCHDOC Revision 120125
Delete UKW-Inductors for Mill	111202	Ryser Daniel			
change blockdiagram title to EF518 XJ Office	110526	Ryser Daniel			

Legende:

- a) Wassertank gross mit 6-Kant Clarispatrone
- b) Flowmeter
- c) Pumpe mit Membranregler
Typ: Sysko SAP.HP4
- d) Kondensator (Z5)
- e) Thermoblock 2010 (230V/1400W)
- f) automatisches Keramikventil (J5)
- g) Brüheinheit clean
- h) Auslaufventil; 4bar (J-Linie)
- i) Drainageventil mit Schrittmotor
- j) Kaffee-Breitenverstellauslauf
- k) Connector V2
HW-Rohr kurz, Aufschäumhilfe

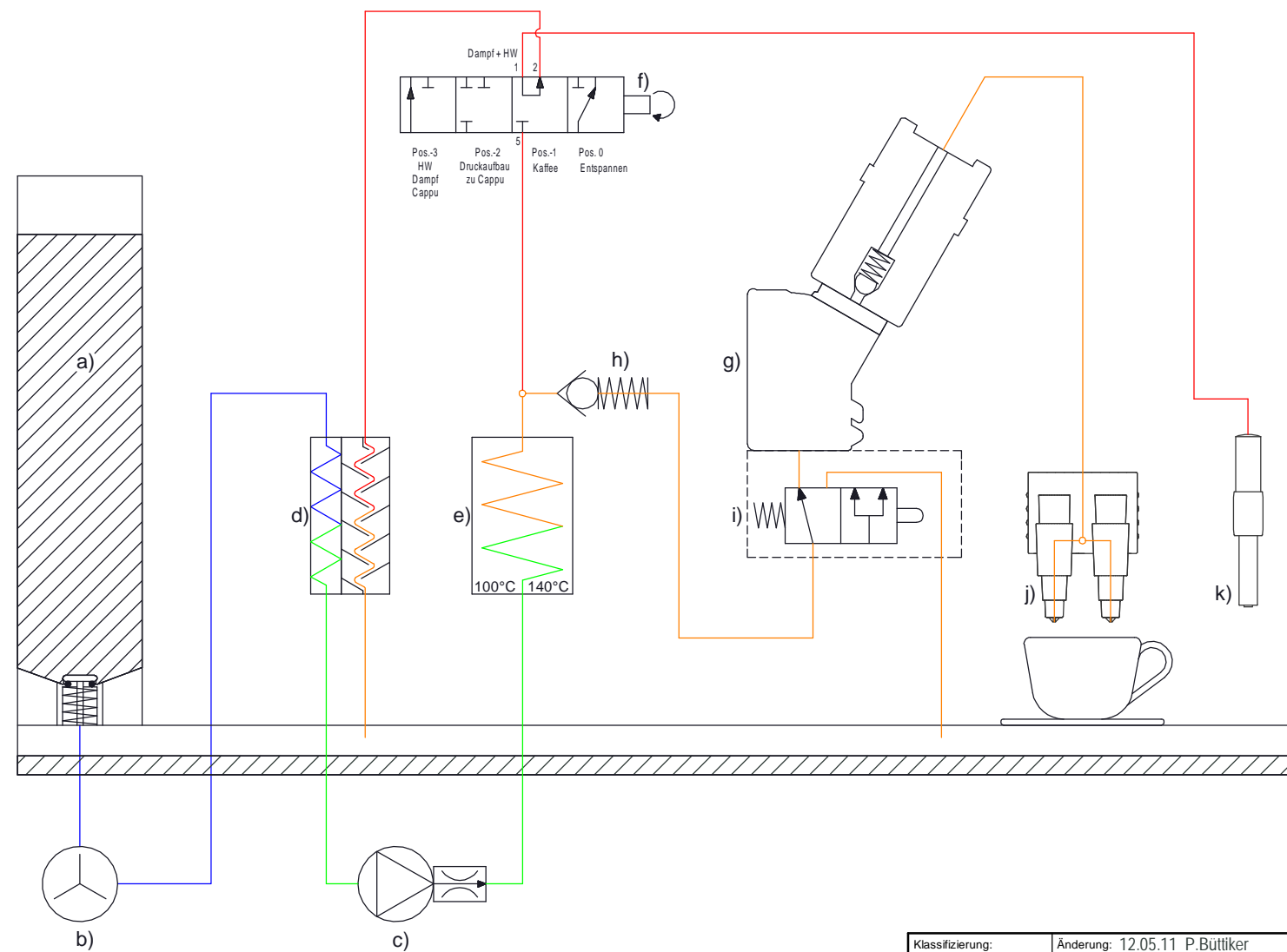

Klassifizierung:	Änderung: 12.05.11 P.Büttiker	Erstellt/Gez.	E.Ullmann	04.11.10	Massstab	mm
		Geändert				
Gewicht:	Material:	Geprüft/Freig.	P.Büttiker	04.11.10	Format	Blatt / Anz.
Rohmass:	Behandlung:	Status:			A3	1 / 1
 Jura Elektroapparate AG CH-4626 Niederbuchstien www.jura.com					Benennung:	
					Fluidsystem XJ Office, EF518, 230V 50/60Hz	
					Artikel-Nr.	
					Zeichnungs-Nr. Index	
					0030N033-ds00,00.01	